



Turnaround

MARCH 2006

©Copyright Reserved AWSA 2005

Newsletter of the Association of Woodturners of South Africa

Chairman: Louis van Niekerk (louisvn@iafrica.com)
Also see the Association website at: www.awsa.org.za

Secretary: Gert Ferreira (gskc@mweb.co.za)
Edited by: Gigi Laidler (gigi.laidler@lando.co.za)

NOTICE OF ANNUAL GENERAL MEETING

Notice is hereby given of the Annual General Meeting of the Association Woodturners of South Africa, to be held on Sunday 30th April 2006 at 15:30, at the Department of Zoology Building, University of Stellenbosch, Merriman Ave, Stellenbosch



Two of Stuart Mortimer's pieces

From the Editor

For a number of readers, this will be the last edition of *Turnaround* that they will be receiving, as the deadline for renewal of membership of the Association for the 2005/2006 year is 31st March 2006, and regretfully, the benefit of receiving news of other turners in the country will fall away, if payment is not received. For the convenience of members who wish to renew their membership, I am attaching the membership renewal form, which does make provision for payment of arrears, where applicable.

Once again I have enjoyed wonderful support from members, with a number of interesting articles, and I wish to extend my sincere thanks for all contributions. By sheer coincidence, two members have submitted articles on the beginnings of this Association and the formation of a Club.

Thank you too, for the membership renewals that are coming in, as are Congress Registrations. If possible

please register *before* the deadline – makes our planning a lot easier, and things run more smoothly when you are here for the Congress. Once this newsletter is out, I will acknowledge all payments.

Excitement is mounting as plans for the Congress are coming together, and the Cape Town team are working flat-out to ensure everything is in place when our friends from afar arrive to share new insights and experiences and memories of past gatherings.

For the newcomers to the Congress, here are some tips to help you make the most of the event:

- When you get your programme, choose the sessions you plan to attend in advance, and if two parallel sessions both appeal to you, ask someone who is attending the alternative session to fill you in afterwards
- Have notebook and pen handy at all times for taking notes – memories are fallible, and there will be a lot to take in and you will be victim of information overload
- Use the opportunities to network over those coffee breaks and meal times – invaluable tips can be picked up “in passing”
- Be prepared to take advantage of some “show specials” that the commercial sponsors might have, and their displays will also offer opportunities to pick up tips and expand your woodworking knowledge, just by seeing what’s available “out there”
- Don’t be scared off by design sessions – inspiration comes from unexpected sources, and sharing ideas with others will take your skills to new and unexpected levels

We look forward to welcoming Congress participants to Stellenbosch in a month’s time. For those who do not have it, the Registration form is available online on the AWSA website, which is once again up and running.

Keep those curly shavings streaming,

Gigi Laidler

From the Chair

Not so long ago, the 2006 conference was something in the distant future and now suddenly it is just around the corner. The registrations are picking up and we expect a large number of members to attend. The Committee has tried to make it as affordable and

interesting as possible, and with two international turners and our own talent on show, how can we ask for more! Don't delay, please forward your registration to Gigi.

At the 2005 AGM a number of issues were raised that still need to be put to bed. At the coming AGM we will have to spend quality time in resolving some of the critical issues facing us as an organization, but also apply our minds on some strategic issues. What do we expect from the organization besides organizing a conference annually, as an individual and as a club? Where are we taking the organization, how and by whom? Probably some of these issues are long overdue. Any input into these issues are welcome.

Looking forward meeting old acquaintances and to meet new friends that share the same interest, namely woodturning.

Let's enjoy woodturning and have fun!

The Cape Town Team
Louis van Niekerk

AWSA Congress 2006

Planning around the 2006 Congress is moving ahead apace. Members should all have received their registration letters by now – if not, please let Gigi know urgently.

AWSA 2006 Congress Summary:

Date: 28 April to 1 May 2006
Venue: Natural Science Building (Zoology and Botany), University of Stellenbosch, Merriman Ave, Stellenbosch.

Costs and Registration:

The all-in congress cost for AWSA members is **R490-00**, which includes:

Congress Attendance Fee	R 345.00
Friday Night welcome/ get-together function	R 40.00
Saturday Night Dinner	R 35.00
Sunday Gala Dinner	<u>R 70.00</u>
Partner's Programme	R 190.00
Sunday Gala Dinner (partner)	R 70.00

Accommodation: Limited affordable hostel accommodation has been booked at a local high school (so book early):

Single, Bed and Breakfast per night	R 120.00
Per person sharing, B & B, per night	R 70.00

For those making their own arrangements a useful website for accommodation is: <http://www.roomsforafrica.com/dest/south-africa/western-cape/stellenbosch.jsp>. or you can visit the Stellenbosch Tourism Information Bureau's website at: <http://www.tourismstellenbosch.co.za/>. Alternatively you can phone Stellenbosch Tourism Information Bureau to make accommodation enquiries and bookings on (021) 883 3584. Reports are that they are

very helpful – but please book soon as accommodation is at a premium.

Guest Turners: Stuart Mortimer and Phil Irons
Programme: Items planned for the programme include a demo by Winston French on Chinese Balls, Allan Ferguson discusses tool-making – some different ideas, while Ken Turner will give us some useful tips on photographing your work. Thys Carstens has agreed to share some of his experience with resin inlays in turning, and the ever-popular Dave Stephenson will bring along his faithful "little lathe" to demonstrate miniature turning, as he does at shows and public events. For a different perspective, Dr Dieter Steinmann, an expert wood scientist, will give us some insights into wood curing and drying. Full details of the programme will be available closer to the time.

International Guest Turners

Our star attraction at AWSA Congress 2006 is Stuart Mortimer and we look forward to hosting Stuart and his wife Linda from Hampshire, England. Stuart is an accomplished award-winning turner and author, and readers of books on woodturning and magazines like *Woodturning* will be familiar with his signature spiral work, and we look forward to seeing some of his decorating techniques "in the flesh".

We are also fortunate that Phil Irons' visit to Stellenbosch for a friend's wedding happens to coincide with the timing of the Congress, so he has kindly offered to do demonstrations and/or give classes while he is here, so we look forward to being entertained by Phil as well.

Stuart Mortimer: Synopsis

courtesy of: <http://www.stuartmortimer.com/>

In 1969 Stuart got his first lathe and from that point he was hooked. Like most turners he turned at school, and built on that from the beginning, learning to cut properly along the way. He soon found that he had a flair for turning, and after retiring he entered and won several National competitions. He started to write for *The Practical Woodworking* magazine, from that point onwards he was on 'the circuit'. He turned professional in 1992 and has enjoyed teaching and demonstrating throughout the U.K., Europe, Scandinavia and the U.S.A.

He has recently moved to Hampshire, England where he has a large well equipped workshop, where he teaches, demonstrates, holds workshops and guests woodturning clubs.

Stuart holds the Authenticated World Record for the Largest bowl turned from one piece of wood at the



American Woodworker shows in Detroit and Philadelphia in 1997. He was assisted by his buddy Steve Blenk a big turner from Seattle.

Stuart is on the Register of the Worshipful Company of Turners and is a member of the Association of Woodturners Great Britain as well as the American Association of Woodturners. He is the author of *Techniques of Spiral Work*, and his first video, *Wet Turning with a Difference* is on sale now.

Vicmarc Lathe at AWSA Congress 2006

Vicmarc Machinery Pty Ltd of Australia and Phil Irons, the Vicmarc agent in the UK have arranged to have a VL300 ESVX Short bed lathe at the forthcoming AWSA Congress.

Here is a brief summary of the specifications:

- 600mm swing over the bed.
- 500mm between centres
- 2HP/1.1Kw motor
- Electronic variable speed with vectored torque drive.
- 3 speed ranges, 10 – 1000, 20 – 2000, 30 – 3000 rpm in forward and reverse.
- Taper roller bearings
- 2 MT head and tailstock with M33 x 3.5 spindle thread.
- Knee bar stop (red bar across the front of the cabinet)
- Integral shavings chute in cabinet
- 300 Kgs weight.
- Lathe footprint 1000 mm x 700 mm
- Standard equipment includes: 4 prong drive centre, revolving tail centre, 150 mm faceplate, knock out bars, faceplate spanner, 300 mm tool rest, indexed locking levers, self ejecting tail stock, 24 point indexing with viewing window, spindle lock and owners manual.

More detailed specifications can be viewed at www.vicmarc.com

PRICE: 35,000 ZAR including an Outboard turning attachment and two chucks worth 6500 ZAR



Phil Irons

Schalk's Challenge

A reminder to Congress participants to bring along a turning – anything from a piece of wood 150mm x 150mm

From the AWSA Committee

The 2005/6 AWSA Committee

Louis van Niekerk – Chairman. louisvn@iafrica.com (021) 913 1470(h)
Graeme Hill - Vice Chairman graemehill@mweb.co.za (021) 794 1639
Gert Ferreira – Secretary. gskc@mweb.co.za ; (021) 559 1409(h)
Gigi Laidler - Treasurer and <i>Turnaround</i> Newsletter Editor gigi.laidler@lando.co.za (021) 797-7755(h) 082 485 8399; Fax: 086 618 3113
Dennis Laidler – PRO/communications dennis.laidler@lando.co.za (021) 797 7755(h); 082 365 2755

National Exhibition of Woodturning

Mention was made in the previous newsletter that the committee have secured the use of the Old Mutual Conference Centre at Kirstenbosch as a venue for a National Exhibition of Woodturning over the Easter Weekend, 14 – 17 April 2006.

This event promises to be an excellent opportunity for woodturners to showcase their very best works in a prime venue, so the committee urges as many members to take advantage, and to participate in this event, as possible.

- The exhibition will consist of pieces which are being submitted for the Instant Gallery at the Congress two weeks later.
- Entry to the exhibition is not compulsory for members exhibiting at the Instant Gallery, and members may enter all, or some, or none of their pieces, submitted for the Instant Gallery.
- All items to be exhibited, must reach Gigi Laidler at: Pearson House, Kirstenbosch National Botanical Garden, Rhodes Ave., Newlands (per courier, or delivered via friend/colleague), or posted to PO Box 308, Plumstead, 7801 by 7 April 2006.
- The Committee will transport items from the exhibition to the Congress.
- Use the form for entries for the Instant Gallery, that was included with the registration form, to register for this exhibition.
- All items must be clearly identified, and this identity must correspond with what is on the registration form.
- There will be no entry fee for the exhibition, however exhibitors will be responsible for any costs of transporting works to Kirstenbosch.
- The Committee reserves the right to withhold items that are deemed to be not of a standard appropriate for a national exhibition, which aims at showcasing the best woodturnings in the country.

- Items may be marked for sale, and a 20% commission on the sale price will be due to Kristenbosch, so items for sale must be clearly identified and the sale price must include the commission.
- The deadline for receiving items for display is Friday 7 April 2006.

From the Members

Nico Swart Exhibition

by Nigel Waters

Introduction

Having recently completed reading the December AWSA newsletter, I was inspired by the manner in which our leading SA turners are making a name for themselves (and promoting SA woodturning) both locally and on the world stage. Well done guys. Within this context I thought it appropriate that the efforts of Nico Swart, in holding a Solo Exhibition of Turned Objects in Port Elizabeth late last year, needed to come to the collective attention of AWSA members.

I have known Nico for some years now and always use the opportunity when in Port Elizabeth on business, to pop in to his workshop for a quick visit. Nico runs Barenesta, a successful and very well organised furniture restoration and production turning business. I have never failed to be impressed with the layout of his workshop, the condition of his machinery and equipment and the meticulous attention to detail in everything he does. With each visit, I resolve to keep my workshop tidier and more organised, but this never seems to materialise. My wife has suggested that I find workshop gnomes that will clean and organise for me in the dead of night, but each visit to my workshop is a stark reminder that they have not arrived – maybe 2006 will be the year that they turn up.

During one of my visits to Nico in early 2005, he disclosed that he was preparing for an Exhibition. This piqued my interest and I was soon engrossed in examining the pieces already prepared and stored (neatly of course) in one of the rooms on the first floor of his workshop.

Preparation

Nico turned 55 pieces that eventually made it into the exhibition. This obviously excludes pieces that either didn't work out or were not considered to be up to exhibition standard. The vast majority of the pieces were turned in 2005 in time that he allocated to working towards this exhibition, beyond the normal working day. I always admire the energy, passion and dedication of the AWSA members that work full time in wood turning production shops and still find the time and enthusiasm to spend more hours in the workshop working on more creative pieces.

Apart from the task of turning 55 pieces; it is evident that a lot of time, thought and planning went into ensuring that the Exhibition was a success. The

Catalogue is evidence of the professional manner in which the whole concept was approached, and included a profile of Nico, a photograph and description of each piece and some adverts (it is good to see wood related businesses supporting turners who support them). The photographs were taken by Jez Rowe and the catalogue was compiled by one of Nico's multi-talented daughters.

The number of articles that appeared in both the English and Afrikaans press during the exhibition period was another indication of good preparation on both Nico's and the Textures Gallery's part. More importantly, this press coverage did much to raise awareness of woodturning as a legitimate art form in the Eastern Cape.

The Exhibition

The exhibition ran from 06 to 22 October 2005 at the Textures Gallery, Central, Port Elizabeth. The official launch took place on the evening of Thursday 06 October and was very well attended by the big names in the Port Elizabeth art community, as well as many of the PE based wood turners. Professor David Jones of the Nelson Mandela Metro University of Technology opened the Exhibition very eloquently, speaking of the ground breaking work being done by Nico in holding the Exhibition. It was also evident from his remarks that an exhibition of this nature had done a lot to refocus the art community on different art forms and broaden their thinking.

The key to the success of the event was that it was pitched as an artistic gallery exhibition in the same way that a pottery or painting exhibition would be – there was no debate as to whether the pieces were art or craft – as is evident from the support and purchases from the PE art community. At the time of writing this article, 40 of the 55 pieces have been sold, 26 of which were sold on the opening night. The exhibition has also led to some follow up business, and it is likely that, over time, most, if not all, of the remaining exhibition pieces will be sold.

Lessons Learnt

It may be more appropriate for Nico to perhaps compile a separate article on this subject for a future edition of the newsletter. However, I will attempt to summarise a few comments Nico shared with me.

1. Sales – very large pieces, as well as plain pieces, no matter how well turned, did not sell well.
2. The relationship with the Gallery owner is critical – allows for flexibility to set up the exhibition for best display of the pieces, particularly since turned objects need floor space rather than wall space.
3. Name every piece – this creates a discussion point with potential buyers and tells a story about the piece. In subsequent interaction, buyers tend to refer to the name (Between the Lines) rather than the product (Railway sleeper bowl).

4. Price List – do not include it in the catalogue. Made available only at the Opening.
5. Be prepared to commit many hours to the process. The time spent turning is only a portion of the total time spent on the planning for and the running of the exhibition.

Looking Ahead

Nico's year ended in a physically and psychologically challenging way. He was diagnosed with a malignant tumour on his right optic nerve, which ultimately resulted in him having to have his eye removed. The one thing that had a big impact on me, as I watched my friend walk this challenging road, was how positive he is. Even in the darkest hour, there was evidence of a gritty determination to not let cancer get the better of him. The adjustment to a significant loss of depth perception cannot be easy for a person who relies on production work for an income, and yet he carries the challenge with poise and grace. Just last week I saw the first physical evidence of a new turning concept we had discussed late last year – I will be watching with great interest what pieces of Nico's make it to the Instant Gallery at the AWSA Congress.

Nico has also ventured into a formalised Woodturning training school which is very professionally organised, both from facility and equipment perspective. The curriculum too, demonstrates that a lot of time and thought has gone into this venture. With the first students already engaged, we wish Nico everything of the best with this and his other ventures. I am sure it won't be too long before I see another Exhibition Catalogue bearing his name.

Nigel Waters

Birth of the AWSA

by Elliott Murray

At the end of 1991 when I thought that I was the only woodturner in South Africa and battled to learn turning out of books and magazines, I read an article in *Practical Woodworking* where the writer spoke of picking up timber near the Chalumna river! This river is 30 kms from where I live, so I contacted the editor to find out where this Alec Jardine lived.

When next I was in Durban I made contact with Alec who was living at Kloof, but was on the point of moving to Port Elizabeth. He had all his equipment packed but as woodturners do, he gave me some lovely timber to take home to turn.

Once he moved to PE we got together more often and started discussing the possibility of forming a national body. Alec said that Schalk van Niekerk had also spoken to him on this topic.

Strand Hardware held an annual woodworking weekend and Alec invited turners from all over the Republic to go to PE in October 1995 to have a chat. There was an enthusiastic response from all except Natal and the Free State, and after having our first demonstrations by SA turners we met and decided

that it would be a good idea to get started. Mike Kaplan designed our logo (with the shavings going in the wrong direction) and drew up a constitution. There was a strong delegation from Johannesburg and from Cape Town, and Alec, naturally, was elected chairman.

Alec set about organising the first congress in Bloemfontein in 1996, where we found a contact (Tommy Bond) and a venue at the Hardware Centre. At this stage Alec's health started deteriorating and he asked me to continue with the arrangements. The venue was not ideal as the business continued in the shop while the demos were in progress, but Bloem is central, and attendance was good. Interest was stirred in oval turning and at our formal meeting. Alec was very impressed by Izak Cronje's grasp of our problems and his proposed handling of them.

It was decided to hold the next congress in Cape Town where Izak, with his experience of overseas congresses and his exceptional organisational ability, lifted the standard of our congresses to where they are now.

John Mills from Durban came to a PE Strand Hardware meeting and persuaded his woodturning section of the Durban woodworking club to join us and they attended the August 1997 congress in Cape Town, and are now a strong branch of the AWSA.

Congresses have been held in Cape Town in '97 and '98, Johannesburg in '99, East London in 2000 and 2001, Durban in '02 and '04 and the Cape Town one is planned for 2006.

As a tribute to Alec Jardine who had a fantastic ability in the use of English, the annual newsletter award, made by Mike and Grant of Knysna, bears his name.

Elliott Murray

On matters of Safety in the workshop

by Nigel Waters

The woodturner's workshop is generally not the most amusing of environments – at least not from the turner's perspective. Woodturning is a solitary experience, uninterrupted by the intervention of other human beings. Machines are good company, except when they occasionally bite and snarl, as various scars on my body can attest to. There is also that hole in the ceiling that serves as a constant reminder of what damage a whirring piece of wood can do at 2000rpm after a cursory assessment of the structural integrity of the 100-year old fence post proved to be incorrect – the flaw running through the wood was quite obvious once I had removed it from its resting place in the ceiling!

While the hole in the ceiling serves its purpose as a reminder, I do have a real trophy in the form of a fibreglass hand and lower arm caste mounted above my band saw as a constant reminder of what a minor lapse of concentration can do when cutting out bowl blanks. A seemingly superficial cut in the top of my

left hand resulted in tendon damage which required my hand being immobilised for a couple of weeks. Attempting to tie shoelaces with one hand is a harsh reminder of the need to take extreme care when working with potentially dangerous equipment. To this day I don't know what happened, despite rerunning the scenario numerous times after the incident to assess what could have gone wrong.

Despite the many (thankfully minor) injuries I have inflicted on myself over the years, it is my wife that generally bears the brunt of the incidents. An astute and somewhat cynical observer of my workshop goings on, she wryly commented after the last incident that seeing me stumbling into the house with my hand wrapped in a somewhat bloodied T-shirt is a good clue that something untoward has happened in the workshop (again!). She has also found me on more than one occasion lying prostrate next to the swimming pool (conveniently located just outside my workshop), with an injured appendage dangling in the water in a pathetic attempt to achieve some degree of pain relief. She knows the routine by now – switch off the still running equipment in the workshop, wrap the damaged part of my body in a towel and head for the Emergency Room. Did I mention that the incidents usually occur on a Sunday afternoon, much to the delight of the local GP's? I have personally funded at least one GP's around the world holiday through Sunday afternoon workshop indiscretions!

On one of my more recent visits to the Emergency rooms, I encountered a young female GP for the first time. Nearing the end of a long weekend of dealing with household mishaps, she was in no mood to entertain friendly woodturning banter. With more roughness than was necessary, in my opinion, she removed the portion of the natural edged bowl that had embedded itself in my arm when it came off the chuck after a particularly fierce dig-in. However, what really hurt was her comment to the nursing assistant that she had had enough of these amateur DIYers attempting tasks that should be left to properly trained professionals. All illusions I had harboured of my turning prowess vanished in a pool of doubt and self pity.

But I was back at the lathe the next week, poking rather tentatively at the injury-inflicting bowl rescued from the vegetation near the pool, where it had come to rest during the dig-in incident.

This goes to show that turners are a resilient bunch, and that not even the wrath of the medical profession can prevent us from doing battle with the metal monster harbouring a whirring piece of wood!

Nigel Waters

A large Bowl Turning Lathe

About ten years ago, after joining the WCWA and starting to turn wood again, I became inspired by an article in *Woodturning* by Ken Sager of New Zealand, who built a large lathe from wood.

Looking at different designs, I soon arrived at the realisation that a VB36 was not in my price range and being a mechanical technician who builds machines for a living, I had better get out of my armchair and put something together. The first machine was a large rough fabrication which has changed hands a few times and is in use by one of our Waterfront turners.

The machines I am now completing is No. 6 (and one of four being built at present). Every time we build a machine we find, and add, small refinements. A drawing and specifications follows:-

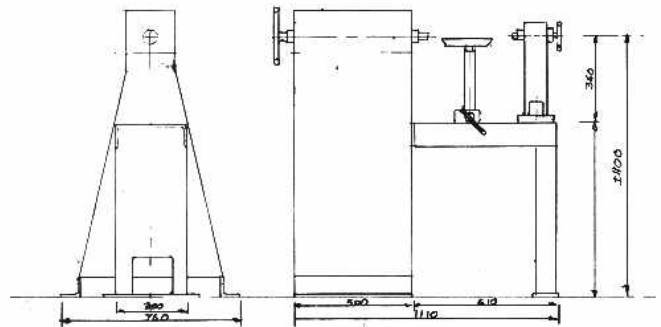

Diagram: A large Bowl Turning Lathe

Machine frame: Mild steel channel and angle fabrication
 Spindle Height: 110mm swing, Ø700mm
 Spindle: Ø50mm B.M.S. shaft with 1½"x6 T.P.I. thread, 2 morse taper in spindle and tailstock
 Drive: 2.2kaath 3 phase motor with L.G. single phase inverter to provide variable speed
 Belt: Poly V-Belt drive
 Tool slide: cam operated
 Accessories: 2 face plates, a spanner, a 300mm toolrest and round bar curved toolrest for large bowls

In the process of developing this design, we found the steel frames would distort as they were welded, so we worked out a way of machining the frames so the bearing surfaces and the table faces would line up accurately. This machining was done on our large Universal Milling Machine.



We chose the 2.2 kW drive as being the largest a single phase supply could accept from home use, and the poly V-belt for minimum vibration.

The final result is a heavy machine with little vibration and lots of power for ambitious large bowl turning. Three of these lathes are in regular use by some of Cape Town's top turners.

Darryl Bailey

Thomas and Stewart Lathe Built by Darryl Bailey in May 1997.

My lathe was the second built by Darryl. I saw an article from a chap in Scotland, who made his own



short-bed lathe, and liked his design for the bed and A-frame. Then I drew up some plans and gave Darryl the specifications, and options that I wanted. We then sat down and ironed out

various problems. I went and bought the motor and bearings, and the steel was mainly purloined from the scrap-yard. The tailstock had to be made a second time before it worked well.

It is in an A-frame format which gives a great deal of stability. I have bolted it to the floor and was going to put a concrete weight in the base but this has not been necessary.



The spindle is 2 inches diameter with a spindle thread of 1½ inch 8TPI; sitting on 2 SKF bearing blocks. The bearings are widely spaced, which gives good stability.

There are two poly-V pulleys with a short poly-V belt to reduce vibration. The motor is 2.2 KW 3-phase.

The speed controller is the greatest thing since sliced bread. Speeds from 50 rpm to 1 200rpm on the one pulley, and 100rpm to 2 400rpm on the other pulley can be dialled in easily. We added a potentiometer later as it is very much easier to just twiddle a knob than punching in



the frequency on the speed controller. There is a jogging facility and reversibility which is great for sanding. The speed controller also has an effect of quietening down the motor.

I have a 24-slot indexing facility on the pulley. A hinged lid covers the spindle which is safer, forms a shelf on top and stops dust getting in.

The bed is short as it is a bowl-turning lathe, and has a swing of 350mm from spindle to bed. The toolrest has a cam-lock locking mechanism



which works extremely quickly and positively. This needed to be machined true before it would slide easily. It has quite a long base to it so I can get in behind a bowl to a large extent.

The tailstock is also "mark 2" and also has a machined base. I have put on a cam-lock anchor and this works easily too. The tailstock spindle is hollow to facilitate boring if needed.

Both head and tailstocks have 2-morse tapers, which are compatible with my small Jet Lathe.

All in all I am very happy with this lathe. Approximate cost R 10 000, with R2700 being the speed controller.

Peter Nicolle

From the Regions

Thank you once again to everyone who has contributed, and for all the encouraging emails and comments I have received.

For those whose region or club is not represented (or absent) in this newsletter – I apologise for the omission – please send me your news for the June 2006 *Turnaround* by mid June, for inclusion in the next newsletter.

It is great to be able to share the following:

Port Elizabeth Woodturners Guild History of the Guild.

Our first meeting was held at the Mill Park Bowling Club on 14 July 1994. This meeting was arranged by Alec Jardine and attended by 22 people.

The first competition, for a turned candlestick holder, was held in January 1995. This was won by Jan Nel of Queenstown.

Alec pressed for the formation of a National Woodturning body, and the "Association of Woodturners of South Africa" was formed in October 1995 with Alec as its first Chairman.

At the 1997 AGM, Alec stood down due to health reasons, and Ben Zeelie was elected Chairman. Alec passed away in January 1998, and is still missed by those who knew him.

Nico Swart became the third Chairman of the Guild in 1998, a position he has held with the exception of 2001, until last year.

Over the years we have had a lot of different woodturning competitions, with many varied winners and some wonderful designs and art pieces.

The Guild has grown and strengthened with a mixture of members of different ages and backgrounds.

Our objectives are to encourage woodturning and train interested people, by arranging demonstrations and talks on woodturning at various venues in Port Elizabeth. We have invited professionals from Industry and Academic Institutions to give us presentations on various aspects, including design,

paint techniques and tool manufacture. The Guild has established its own library, with books, videos and magazines that are available to all members.

In October 2005 the first woodtuning exhibition was held in Port Elizabeth by Nico Swart. This was closely followed by sixteen pieces from various members being exhibited at EPSAC, both these exhibitions have created a lot of interest from the public.

Guild Meetings are held on the third Thursday of every month, usually at 22 Dobson Street, at 7 pm.

If you are interested in joining, or have any further questions, please contact:

Nico Swart (041) 487 0487

Jez Rowe

Jez Rowe new VC

Nico Swart is Chair

Jez is also Newsletter Editor.

Port Elizabeth Woodturners' Guild: Meetings are held at 18:30 for 19:00 on the third Thursday of every month, unless otherwise advised. Contact Nico Swart: (041) 583 3344; barenesta@absa.co.za

Planned Activities:

Venues: Nico's Workshop 22 Dobson Street
Nic Riche's Workshop 5 Dobson Street
Strand Hardware 303 Govan Mbeki Avenue
Meeting Time: 18:30 for 19:00PM

16th March 2006

Nico's Workshop

Talk: Theresa Hartman who is a lecturer in design at the NMMU will give a talk on creativity.

Demo: Sharpening by Mr Hilton Harper from Industrial Saw blade services. Discussion and demo on tool sharpening Jigs.

20th April 2006

Strand Hardware

Talk: Mr Van Niekerk from Ibayi Timber to give a talk on the drying of wood

Demo: Andre Esterhuizen from Strand Hardware to demonstrate the Router Lathe.

25th April 2006 (Please note this is a Tuesday)

Nico's Workshop

Time: Approximately 18:00PM TBC

Demo: Stuart Mortimer from the UK will give a demonstration of his work.

18th May 2006

Nic Riche's Workshop

Talk: Jez and others to give a report and instant gallery slide show from the 2006 AWSA Cape town.

20th May 2006 (Saturday)

Nico's Workshop

09:00-12:00AM A morning workshop for all.

Bring your problems and tools along. Lathes and help will be available.

12:00-13:30 Bring and Braai.

15th June 2006

Nico's Workshop

Talk: Special Composites will give a talk on resins for inlaying and turning.

Demo: Metal spinning by Friedel Luders and Jonny Kable. Tools and video supplied.

16th June 2006 (Friday Public Holiday)

Nico's Workshop

09:00-12:00AM A morning workshop for casting and inlays. Participants may bring along a turning ready for inlay.

Demo: Ashwin Ramhith to give demonstration on resin casting and practicalities thereof.

Turners of the Natal Midlands Woodworkers Guild

The woodturners interest group has been very active since September with members arriving at meetings every month clutching the cherished items that they have made as part of the homework assignment. We have also visited the Durban Guild, put on a public demonstration of wood turning and have demonstrated at the Durban Guild.

This Group of 16 regularly has 10 to 12 meeting on the third Saturday afternoon of each month. The interchange of ideas, knowledge and skills has been tremendous with the ability of every member showing improvement.

To create an awareness of woodturning as a hobby and to attract new members we got together with Braziers a local tool supplier who provided four lathes for our members to demonstrate on one Saturday Morning in December. This event was well attended by the Pietermaritzburg public and resulted in us gaining two new members and Braziers selling a lathe, chucks and other wood turning tools.

Winston French demonstrated the turning of a spiked star within a ball to the Durban Guild in January and has now been asked to demonstrate this at the AWSA Congress.

The setting of homework between meetings has really brought out the best in our members with a variety of scoops, gavels, tops, lidded boxes, bowls and balls being produced and presented at our monthly get together.

In order to develop a broader base of competent turners we are now looking at taking this a step further by putting together a more structured programme that will continuously extend each of our members whatever their present level of competence. It is hoped that this will encourage each member to tackle projects that they would not normally undertake and to strive for perfection in all aspects of woodturning.

Natal Midlands Woodworkers Guild – contact Clyde Neumann: (033) 343 4433 ; neumann@mweb.co.za

Clyde Neumann

Knysna

Contact Dave Stephenson: gleneden@telkomsa.net

Witwatersrand

The WWA turners are still looking for a club-house. Hardware Centre has agreed to accommodate us in the interim.

The date and time for monthly meetings remain the first Monday of the month at 18h00.

We will have a presence at Hobby-X from 2 to 5 March, in co-operation with Hardware Centre, as in previous years. Our display stand is in storage with all our other kit, so the display of turnings will be somewhat reduced this year.

Visitors are welcome, but should phone to confirm arrangements beforehand. The web site (<http://mysite.mweb.co.za/residents/tpope/homepage.html>) will be kept up-to-date with any developments. For the main club meetings, our secretary Roger Matthews can be contacted on: (011) 465 9009(h), 082 893 0193 rbmatthews@hixnet.co.za. For the turning section, the chairman of the turner's section, Chris O'Connell, whom many of you have met at congress can be contacted on: chrisoco@icon.co.za (011) 803-4198 082-900-5353

Trevor

Western Cape Woodturners Association

Visitors to Cape Town.

Those of you who are travelling to Cape Town are always welcome to visit us. Should any of you wish to meet up please contact one of our committee members to coordinate and get the address.

Chairman	Louis Van Niekerk	louisvn@iafrica.com 082 885 0347
Vice Chairman	Graeme Hill	graemehill@mweb.co.za 083 252 4642
Secretary	Eric Thornton	notnorth@mweb.co.za 082 465 4237
Treasurer	Hugh Scholtz	hascholtz@worldonline.co.za 082 895 0631
Bulletin Editor	Ken Turner	kturner@iafrica.com 083 651 4993

Woodcrafters Association of Durban

Contacts:

Charles Thatcher 084 4445532
Perrie Bullock 082 4427114

Greetings from Durbs, I trust you all had a great Christmas and new year. The year ended on a high note with our very successful Annual Challenge at which there were 43 challenge entries and many more display entries. To keep it simple, there were only 2 categories, furniture/cabinet making and woodturning, both divided into 3 sections, novice, intermediate and advanced which were each weighted to level the playing field. The judges invited from the Midlands Guild did an excellent job of assessing the entries and determining the ultimate winners.



John Ramsden an intermediate turner took the Gold in the with his Loquat platter

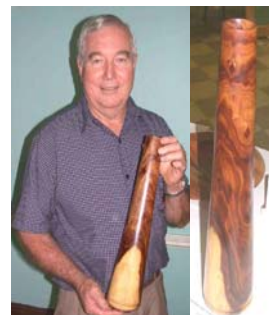

Perrie Bullock's deep hollow vessel out of Pencil Cedar earned him the Silver



Phil Cadman's Ministein piano in Ebony and Ivory, took the Gold. The attention to detail astounding, including brass castors, pedals and keys that all work.



Neil Knight earned Silver for his Maple frame with perfectly executed mitred corners and finishing.

The year started well with Winston French giving us a great demo on turning a spiked star, which was very impressive and a refreshing change from the norm. Next time he has promised to turn us some Chinese balls! extreme, to the back to basics, John Mills demonstrated "How to choose and prepare wood for the lathe" it is always amazing that how even the most experienced come away from these 'back to basics' demos saying they learned something new.

On 20th March Perrie Bullock will be showing us how to turn a platter. April's meeting has been cancelled due to the Easter weekend and AWSA.

Charles Thatcher

News from the East London Woodturners Guild.

Our club continues to meet on the 4th Wednesday of every month (except in December) at about 17.30 in the woodwork room at the Hudson Park High School in Devereux Avenue in East London.

Our membership at the moment is standing on about 42 with a committee of 8. Our library (of which I am the librarian) is well stocked with Woodturning magazine, Fine woodworking magazine, books by various well known turners (including Stuart Mortimer) and turning videos.

In February we had our first competition of the year which was to turn a bowl that had to be made out of Jacaranda. This competition was well supported by the members with about 16 entries received. The winners all received Woodoc products kindly donated by Servistar. Our next competition will be held in August the subject of which has still to be decided on. On the 25th February our guild had a public demo at the Servistar Demo Day, I could not help out due to having church matters to attend to for the whole day, but according to our secretary the day went off very well with quite a huge amount of public interest.

Gavin Knowles

woodyone@polka.co.za; (043) 726 6749

News from the Admim Capital Pretoria
Pretoria Woodworkers Association

March Woodwork event will be of all aspects of turning with the emphasis on turning for general woodwork projects.

The turning group has been invited to exhibit with wood carvers in the Eastern

suburbs of Pretoria.

A sharpening session was held on the 1st March at the home of At Smit. It was very well attended and proved again that sharp tools are a must.

Members of the turning group have been invited to demo at Leeupoort crafters 170 km north of Pretoria. It will take place some time in April.

Several new members who have joined the Woodworkers Association have also joined the turners sub-group and are currently undergoing turning courses presented by Keith Jones and At Smit

Turning Homework 2006

Items marked B or I or A are beginner, intermediate, advance.

FEB Table lamp or Standard Lamp (I), Servetring (B), Stoelpote (pommel) (B), Eksentries, veelvuldige senters(A), Tool handle (B), Vingerhoed(B)

MAR. Item geheel en al met slegs een draai gereedschap stuk gemaak van begin tot klaar (skuurpapier nie toegelaat) (B), Door wedges (B), Out of Pretoria (A), Dun wand >4mm (A), Natural edge with or without bark (I)

APRIL Gavel(B), Item met tekstuur dekorasie, brand, pierce, kleur, kerf, net wat u wil(I), Items according to specified dimensions, Lidded, Finial or Trunion box (B,I), Thin stemmed wine glass / Goblet (B,I) Winged bowl (A)

MAY Spatula(B), Two of a kind, one hard wood one soft wood.(B,I), Face plate item more than 200mm diameter(I), Spinning tops all kinds (B), Squared edged bowl or platter (I,A)

JUNE Laminated or segmented item (A), Fruit (B), Weedpot (B), Candlesticks (I,B), Stamper en vysel (I,B), Platter with inlay (A)

JULY Deep hollowing 120mm or more (I,A), Wall hanging, Plaque (I,A), Dowel 12mm x 450mm (B,I,A), Honey dipper(B)

AUGUST Out of Africa (A), lace bobbin (I), Baseball bat (B), Brief oopmaker (B), Pen (B,I), Pencil (B,I), Perfume atomiser (B,I)

SEPTEMBER Peppermill / saltmill (B,I), Paper towel rail (B), Miniature turned item >10mm (B,I), Deursigtig dun(A), Blom (B,I), Shallow bowl with under cut rim (I,A)

OCTOBER Cup and saucer one piece (I,A), lace bobbin (B,I), Bottle (B), Balls (I), Daaistuk met n tema (B,I,A)

NOVEMBER Cotton reel holder (B), Walking stick / traditional weapon (B,I A), Scoop / spoon / salad spoon & fork (B,I), Mushroom (B)

DEC Rolling pin (B), Garden dibber (B), Slaaibak (B,I), Eierkelke (B), Small bowl (B)

- You may do any of the above items for the month or all of them.
- Please remember that OWN choice is applicable each month.
- Please try and make one TOY per month or one in two month's thank you.
- Detailed drawings with sizes to be handed out in Feb for April tasks

Public holidays

21 March Sharpening of tools

17 April Finishing of turned item

27 April Chucking , stock preparation , custom made tools.

Did you know ! ?

That the Woodworking Association of Pretoria is the oldest of the Woodworking/Woodturning clubs in the country.

That the lower peaks of the Magaliesberg in Pretoria is higher than the top of Table Mountain.

Woodworking Association of Pretoria: Editor of *Tambotie*:
Louw Trichardt: 012 653 1874; louwmarie@icon.co.za

Roger Courtney

Lower Albany Woodworkers Guild

Lower Albany Woodworkers Guild: Don Wood (Port Alfred), (046) 624 4049; Arnold Rudolph, President. (046) 624 2469.



ASSOCIATION OF WOODTURNERS OF SOUTH AFRICA

MEMBERSHIP FORM: 2005 / 2006

Remittance:

Arrears Membership (2004/05): Association of Woodturners of South Africa (AWSA) [R60] R.....

Current Membership (2005/06): Association of Woodturners of South Africa (AWSA) [R80] R.....

WCWA members' shortfall (who paid R55 to WCWA): R.....

Total Remitted: R.....

Method of payment [Cash / **Cheque** (Give number) /
Electronic Transfer or **Direct Deposit** (date)]

Cheques should be made payable to: **Association of Woodturners of SA.**

Direct deposit into the account go to: ABSA Bank, Cresta Branch, code 334 705,
Current account #40-5156-7354. Please **use surname and initial as Reference** to facilitate identity of payment.

Kindly complete this form and return it to Gigi Laidler by email, with proof of payment, to (gigi.laidler@lando.co.za) or
fax the deposit slip and this form for attention of Gigi to 086 618 3113, or mail to: Gigi c/o PO Box 308, Plumstead, 7801.

Personal Details (exclusively for our database, not to be made available to any outside party whatsoever):

Name: _____ Spouse: _____

Address: _____

_____ Code _____

Telephone + code: (H) _____ (W) _____ (C) _____

Fax: (F) _____ E-mail _____

Preferred method of receiving newsletter (please mark one choice):

Post

Email