

Tips:

Cutting abrasive paper by Jim Kingshott, Heatherbrae workshop, Surrey, U.K.

Having for some time torn sheets of abrasive paper in half by folding them and hoping the tear would follow the fold, which it never does, thus wasting abrasive paper, I made the appli-ance shown here from a scrap of ply, a worn 305mm hacksaw blade and a mahogany outcut.

The sketch is self explanatory. The hack-saw blade has the set ground off so that each tooth is a sharp point. In use, the paper is pushed against the stop, held down flat with one hand and torn by pulling it down across the blade with the other hand. As I often use a quarter of a sheet, I scribed a line on the board to line the paper up for the second tear.

This tip is from the book "Practical tips for Woodturners, The best from Woodturning magazine.

What's On:

Club Meetings:

> Club Meetings are held at the workshop of Timber Warehouse SBDC Commercial Rd on the **4th Wednesday of every month (Not the 5th Wednesday)**. Members gather from 17.15 and proceedings usually commence by 17.30. Meetings officially end by approximately 19.00, but members are welcome to chat for a while while thereafter (while they assist with the tidying of the venue!)

Beginners classes for members new to turning are usually held on the first Wednesday of the month. Please contact Andy Knight at Club meetings.

Details of content of forthcoming meetings is as follows:

> 23rd April
- How to turn legs for a small stool and how to drill the holes in the stool top for the above legs. Demo by the Editor.

Activities and Notice Board

> Ulrich still has 1 Large and 2 Xtra large club golf shirts left. See Ulrich at club meetings.

> **Your club fees are now due and payable:**
R75 for Workers.
R50 for Students.
R50 for Retired people.
Please see Ulrich at club meetings.

> If you are a pensioner or a retired person, did you know that you can have a cup of tea or coffee and cake and cocktail sausage rolls served by Gloria or Joan at Builders Express on the 1st Wednesday of the month?

> The 12th national congress of the Association of Woodturners of South Africa will be held on the 4th to the 6th July 2008 at the University of Kwa-Zulu Natal, Pietermaritzburg. Start saving for it **NOW**. Only 2 months and 20 days and counting to go.

> The item to make for the May competition is a three legged small stool. Get busy.

Wanted or for sale:

This column is for any woodworking/turning item which you would like to sell or buy. Please contact me (see below)



See next months newsletter for more on Simon.

Please address any correspondence to:

The Editor
(Gavin Knowles)
EL Woodturners News
10 Bowen Street
Cambridge West
5247
Telephones:
043-726-6749(h+w)
e mail: Woodyone@
polka.co.za

East London Woodturners News

April 2008

Editorial

It has happened again !! Just when I was all ready and preparing to attend this years congress in Pietermaritzburg, I have all of a sudden became busy with woodworking jobs. I am presently busy with a cabinet, one meter six high by one meter two long by four hundred and sixty millimeters wide made from solid Oak for our churches meeting room to house the sound and projection equipment. This cabinet which is to be built in two sections is to have thirty millimeter dovetail and finger joints on the corners of the framework. I have just completed with the construction of section A and have cut the dovetail and finger joints by hand !!, I have not got the luxury of having a WOODRAT or a Leigh dovetail jig, (if anyone knows where I could get a dovetail jig, PLEASE contact me). The four door frames of this cabinet also made from solid Oak is to have mitred corners and fitted with sandblasted glass. I have also got to make three very larry presentation boxes for another customer also with either dovetail or finger joints on the frame work. So I need the dovetail jig like yesterday.

The fishing rod factories are also giving me a hard time. After completing 100 parts for the factory in Arcadia, another factory in Beacon bay has also came on line for butt feet parts. They ordered and I made 50 parts for this factory and delivered on Monday. The Wednesday at almost 5, just before I was leaving to go to the woodwork meeting, the lady contacted me with another order for another 50 which is pending. I have now got all three factories that I make parts for. While all this is going on I still have to lose 6 hours a week due to municipality / Eskom's nonsense. I have installed one of my 625 watt U.P.S. / battery back up systems in the machine shop so that I can at least have light to attend to non machine activities.

→ → 2

The March meeting was attended by 15 members again. There were no items for the display table. The demo for the evening consisted of the turning of a goblet with a captive ring by Ulrich. A piece of syringa of about 60 mm x 200 mm was held between centres. The trick to goblet turning is to keep the pith of the blank out of the centre of the blank. Rough down the blank with the spindle roughing gouge. Relieve some of the wood from the centre of the wood where the spindle of the goblet will be. Mount the goblet blank in the shark jaws of the Nova chuck. Drill a 8mm hole to the depth of the cup. Hollow out the cup with the spindle gouge. Ulrich would sand and finish the cup at this stage. Turn the outside of the cup using the spindle gouge and start with the stem of the goblet. Position the portions where the captive rings will be. Turn the outside of the rings (Ulrich only made one ring) with the skew chisel. Separate the ring from the stem with the skew chisel in the absence of captive ring tools. Turn down the stem using the spindle gouge then the skew chisel. Sand the stem and the inside of the ring with a strip of sand paper stuck onto the stem. Turn the base of the goblet and part off with a thin part off tool. This would be a nice item to make for an upcoming meetings display table (see how many rings you can make).

News from the woodwork meetings. Our new woodwork meetings on the second Wednesday of the month is starting to grow. At the February meeting Andre Esterhuizen from Strand Hardware, did a demo on the table saw and showed us quite a few jigs that he uses. At the March meeting Willem Westraad from W4 Designs in Beacon Bay gave us the complete run down on hand tools, planes, chisels, saws and sharpening. He showed us the correct way to hold a saw and how to stand while sawing. At the April meeting we met at W4 Designs. Willem showed us a Husqvarna bandmill that is used to plank logs. We saw the home made solar kiln that Willem built. In his joinery section we saw a huge surface sander and a long band sander. There was a bandsaw with a throat of about 1m and height of cut about 400mm. The length of the blade is 5400 mm. We saw a domino machine that makes slots for end jointing. His turning room contained 4 lathes that included a T124 copier. The machine that I was drooling over was the WOODRAT jointing system, Oh I wish, I wish. Cheers. *Gavin Knowles.*

Advice on how to, how not to, and what I'd done wrong. Simon remembers the apprehension and reluctance that preceded his first club meeting.

So, Marilyn had bullied me into this stupid, messy, potentially dangerous hobby. Now, Harry Middleton - the bloke who had patiently taught me to turn when I really ought to have given in - was putting pressure on me too.

Every time I saw him - and I was having a turning lesson each week Harry constantly and without fail encouraged me to the point of nagging, to at least pay a visit to his woodturning club.

I really didn't want to go, I was 22 and Harry was retired. If all woodturners were of the same age then I wasn't going to have a very good time. I got on really well with Harry and still do, but a room full of old-age woodturners for hours at a time was not my idea of a good night out.

I'd fobbed him off for months with this excuse or that, because I really didn't want to go.

I owed Harry. Without his expert guidance, encouragement and gifts of wood and tools I would have given up completely.

Woodturning would have been added to my long list of cast-off hobbies and another long discussion with Marilyn in which I'd probably have to apologize for yet again wasting a shed load of money we didn't have.

I was going to have to go to this club; my wife thought it was a good idea too, so it was inevitable.

Harry had been a professional turner for quite a while and had started West Riding Woodturners in conjunction with Bill Newton by means of a simple advert in a local paper and on radio.

This had been a year earlier - I suppose around the same time as I started turning. Membership had slowly increased until, at the time I was being 'encouraged' to go, at least 30 turners met once every couple of months in a room above a pub to talk wood stuff.

Getting better

It wasn't that I thought my turning wasn't presentable, I was getting better at it, a lot better in fact.

I knew I was becoming good because people were saying things like "Nice bowl/ lamp /cord pull," or whatever instead of the usual "Nice piece of wood," as folks do when the turnings rubbish.

Anyway, Marilyn said that things were improving, folk at work were happy enough to take home free bowls and the like and I wasn't hurting myself half as much. I must have been improving.

So it was with heavy heart I apprehensively told Harry I'd go to the next meeting of his club.

How bad could it be? Just one meeting every two months in a room above a pub with 30 or so geriatrics. When you're 22 everyone over 30 is old and odds on this lot were well past 30.

In those days - and still in some areas today - the image of a woodturner was of an older, bearded man with glasses, a paunch, flat cap, pipe, braces to either side of the paunch, string belt and a peculiar smell. At least that was what I expected and, in most cases, I wasn't far off the mark.

I already had a flat cap - they were de rigeur at the time - and experimenting with a pipe sounded fun, but that was as far as I was prepared to go.

The evening arrived, I was to meet Harry at the pub, he said I was just to turn up and join in, but he'd be there before me anyway, so it'd all be okay.

Casually dressed and with flat cap - I'm still not comfortable with the pipe anywhere but at home - off I went. Harry wasn't there!

Casually dressed and with flat cap - I'm still not comfortable with the pipe anywhere but at home - off I went. Harry wasn't there!

In the club

However, 30 or so strange men were there, all chatting in clumps, arranging chairs or unwrapping turnings. I was out of my depth. The stuff I was seeing was far removed from the stuff I was doing. All I'd really had to compare my stuff with were the few bits of Harry's stock I'd seen at his workshop, stuff I'd attempted to copy. I'd never really experimented with anything else.

I'd been more concerned with not hurting myself than with designing things until I saw what others were turning, and I'd never really considered shape or form. I was nowhere near as advanced as I thought I was. I did have youth on my side though. The next youngest bloke there was between 35 and 40, I was but 22 and had lots of time and much better dress sense, so things weren't all bad.

I was made very welcome; lots of folk made time to have a word and Harry did eventually appear and introduced me to some people. I did feel very young and was a bit cheesed off that, although I'd obviously come a long way since starting, I still had a long way to go to reach the level that some of these turners were at.

Still, I went home inspired; I'd seen some things to copy at the first available opportunity, been given some advice on how to and how not to and what I'd done wrong.

I'd learned where wood yards were; which yards were having weekend sales aimed directly at turners; been invited on a couple of trips - subject to joining the club of course - and was told about a hands-on day they were having where we could all join in and have a go and also see how others went about their hobby.

Brilliant! I'd join at the next meeting. I hardly noticed that they were all really old. My problem at the time was shyness, I'd avoided going as I was shy, also I stammer so I don't like meeting folk. No, that's not true, I like meeting people, I avoided it because of the speech impediment.

Turners don't care who you are or what ails you as long as you share their interest. They were all pretty nice and mega helpful. I ought to have joined at the first asking but people my age then always think they know best!

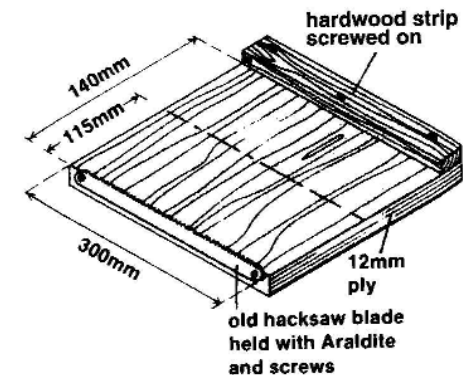

The picture for this months tip.